

环保物料

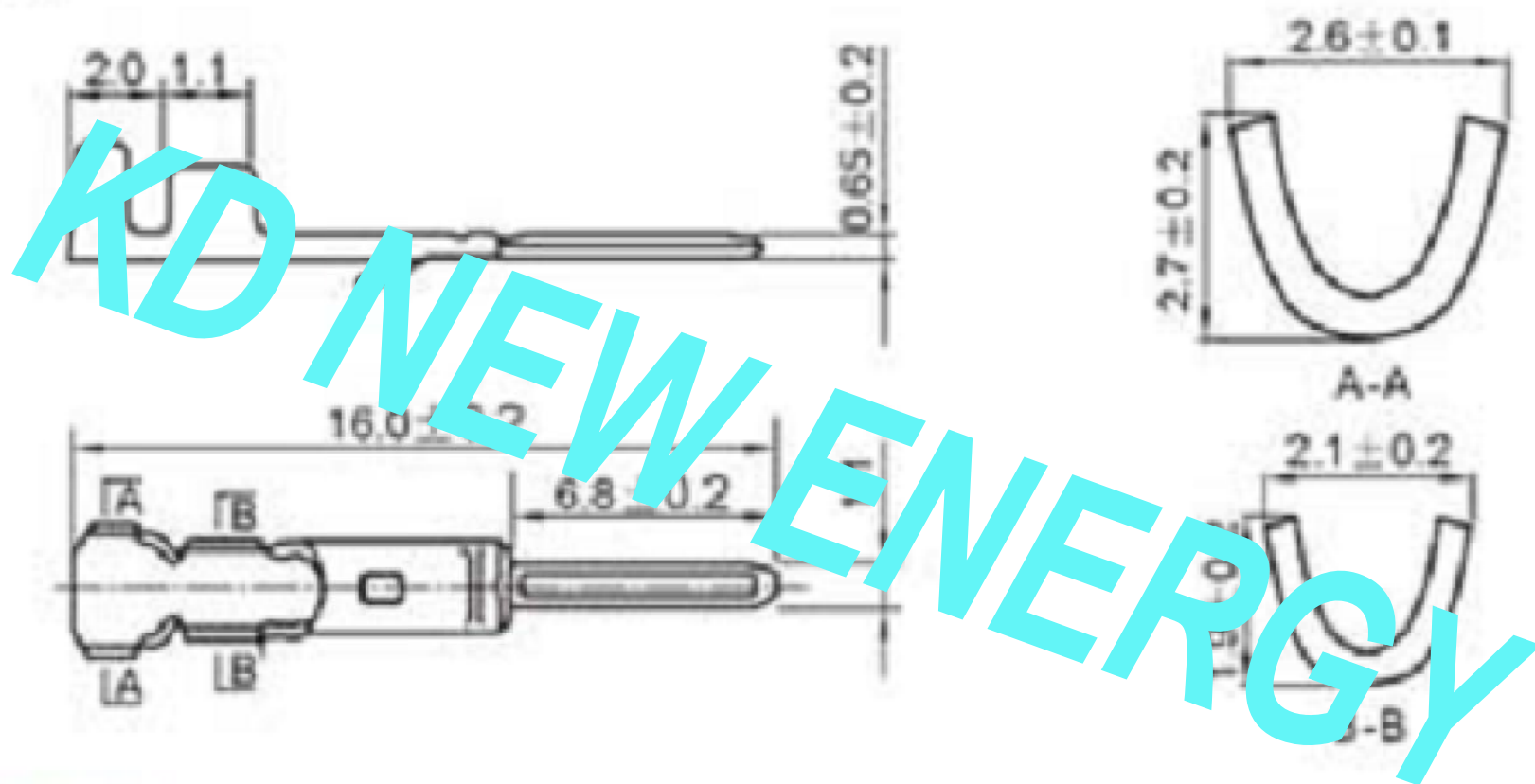

NOTE:

1. MATERIAL: BRASS, JIS C25191R-H , HV 200° ±5°
T=0.20mm
2. Dimensions to be checked by QC
3. wire range: AWG #22-#28

				GENERAL TOLERANCES		SCALE: 1:1	NAME	DATE	东莞市康导新能源科技有限公司 DONGGUAN KD NEW ENERGY TECHNOLOGY CO., LTD. 公司地址: www.dgkonne.cn 公司电话: 0769-85337533 邮箱: 2850175986@qq.com 公司传真: 0769-85392827	PART. NO: SYP-AT	
				LINEAR	ANGLES					APPROVED	
A0	新图面发行	2018.12.06		UNIT: MM	0.00±0.15	X° ±3°	DESIGNER				TITLE: 2.50mm pitch Crimp Terminal
REV.	REVISION RECORD	DATE	SIZE: A4	0.000±0.08	X° X'±2°	DRAWN	肖丽娟	2018.12.06			