

环保物料

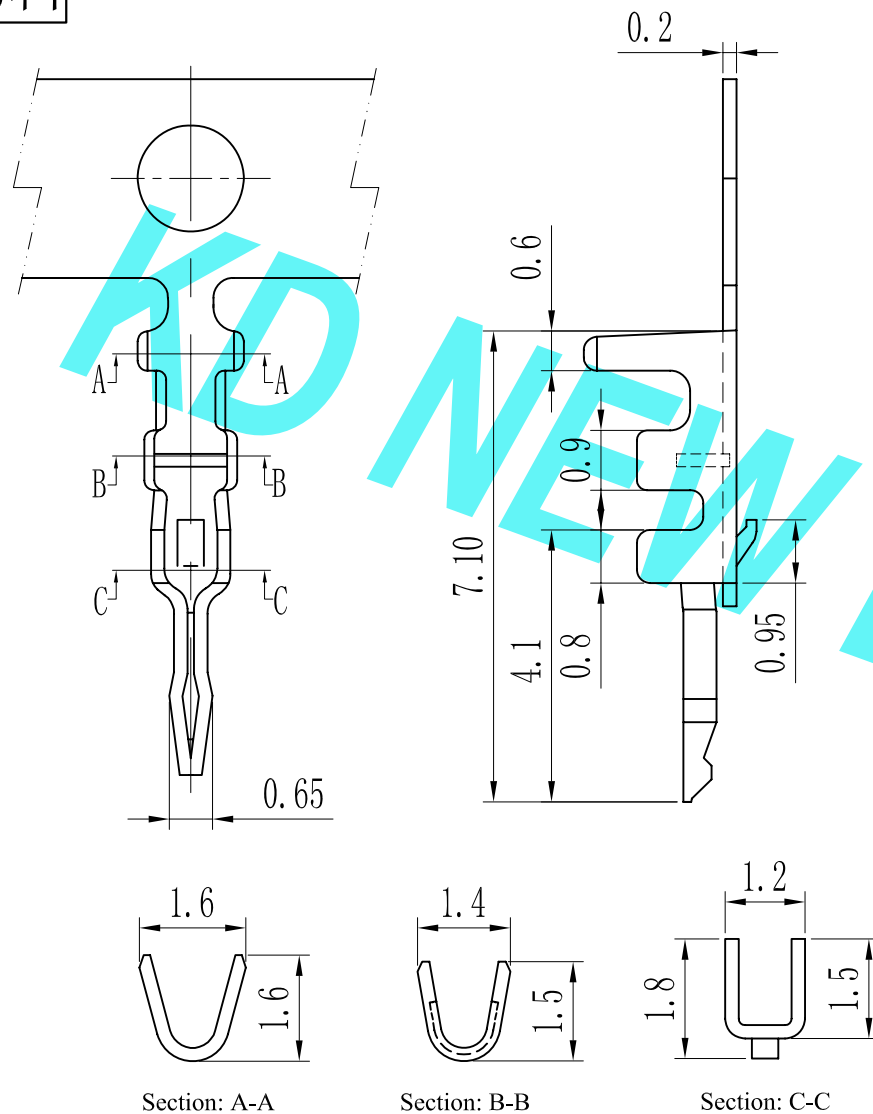

NOTE:

1. MATERIAL: Phosphor Bronze, JIS C25191R-H, HV 200° ±5°
2. Along any portion of strip, allowable camber is 0.04mm per 1000mm length max. And allowable twist is 45° per 1000mm length max.
3. All corners and radii have a maximum Radius of 0.1mm unless otherwise specified.

				GENERAL TOLERANCES		SCALE: 1:1	NAME	DATE	东莞市康导新能源科技有限公司 DONGGUAN KD NEW ENERGY TECHNOLOGY CO., LTD. 公司地址: www.dgoonne.cn 公司电话: 0769-85337533 邮箱: 2850175986@qq.com 公司传真: 0769-85392827	PART. NO: 1.5T-5-T (SZN)		
				LINEAR	ANGLES	APPROVED				DWG. NO:		
A0	新图面发行	2018.12.04	UNIT: MM	0.00±0.15	X° ±3°	DESIGNER			TITLE: 1.50mm pitch Crimp Terminal		REV: A0	SHEET: 1/1
REV.	REVISION RECORD	DATE	SIZE: A4	0.000±0.08	X° X' ±2°	DRAWN	肖丽娟	2018.12.04				