

环保物料

Pin数	尺寸A	尺寸B
4	7.50	10.00
5	10.00	12.50
6	12.50	15.00
7	15.00	17.50
8	17.50	20.00
9	20.00	22.50
10	22.50	25.00
11	25.00	27.50
12	27.50	30.00
13	30.00	32.50
14	32.50	35.00
15	35.00	37.50
16	37.50	40.00
17	40.00	42.50
18	42.50	45.00
19	45.00	47.50
20	47.50	50.00
21	50.00	52.50
22	52.50	55.00
23	55.00	57.50
24	57.50	60.00
25	60.00	62.50
26	62.50	65.00
27	65.00	67.50

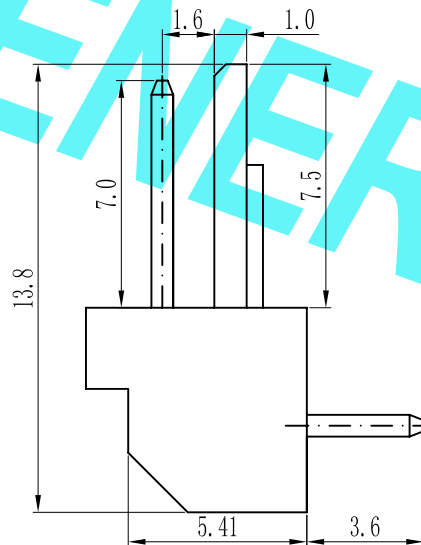
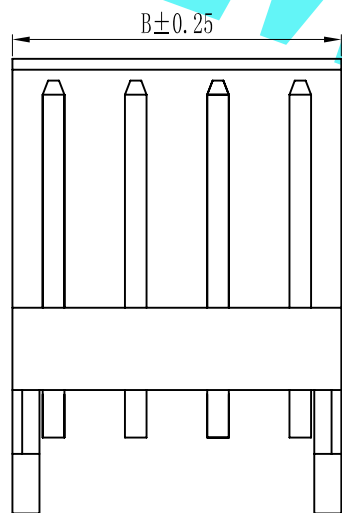
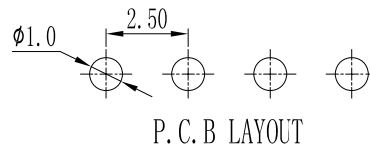
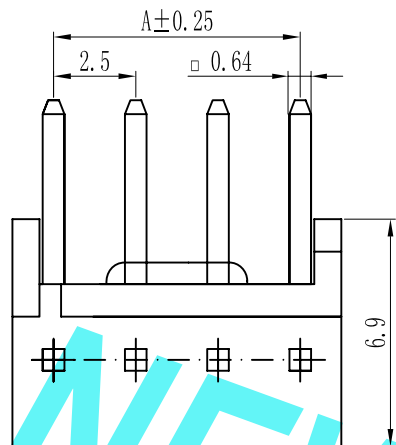

技术参数 SPECIFICATIONS

- ◆间距: 2.5 Pitch:2.5
- ◆适用线规: AWG#22-#28
Applicable Wire:AWG#22-#28
- ◆额定电压: AC, DC, 250V (有效值)
Voltage rating: AC, DC, 250V(rms)
- ◆额定电流: 2.5A, AC, DC (AWG#22)
Current rating:2.5A, AC, DC (AWG#22)
- ◆耐压值: 800V AC/minute
Withstand voltage:800V AC/minute
- ◆工作温度: -25℃~+85℃
Working Temp:-25℃~+85℃
- ◆绝缘电阻: $\geq 1000M\Omega$
Insulation resistance: $\geq 1000M\Omega$
- ◆接触电阻: $\leq 10m\Omega$
Contact resistance: $\leq 10m\Omega$

材料 MATERIAL

- ◆绝缘体: 尼龙66, UL94-V0
Insulator:Nylon66 UL94-V0



GENERAL TOLERANCES

LINEAR	ANGLES
0.0 ± 0.25	$X^\circ \text{ REF} \pm 6^\circ$
0.00 ± 0.15	$X^\circ \pm 3^\circ$
0.000 ± 0.08	$X^\circ X' \pm 2^\circ$

SCALE:
1:1

NAME

DATE



东莞市康导新能源科技有限公司
DONGGUAN KD NEW ENERGY TECHNOLOGY CO., LTD

公司网址: www.dgoonne.cn 公司电话: 0769-85337533
邮箱: 2850175986@qq.com 公司传真: 0769-85392827

PART. NO:

1825

DWG. NO:

TITLE:

2.50mm pitch Single Wafer

REV: A0

SHEET: 1/1

A0 新图面发行

2018.12.06

UNIT: MM

0.00±0.15

X° ±3°

0.000±0.08

X° X'±2°

DRAWN 肖丽娟

2018.12.06

REVISION RECORD

DATE

SIZE: A4

DRAWN

肖丽娟

2018.12.06

2.50mm pitch Single Wafer

REV: A0

SHEET: 1/1