

环保物料

Reference Informations:

*Material: Pin: Brass/Gold-flash

Wafer: Nylon 6T, UL94V-0

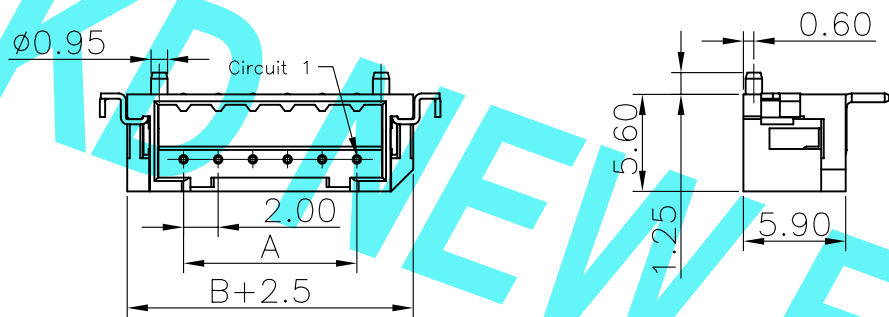

Dimensional Information:

Part No.	Dimensions	
	A	B
2P	2.00	6.00
3P	4.00	8.00
4P	6.00	10.00
5P	8.00	12.00
6P	10.00	14.00
7P	12.00	16.00
8P	14.00	18.00
9P	16.00	20.00
10P	18.00	22.00
11P	20.00	24.00
12P	22.00	26.00
13P	24.00	28.00
14P	26.00	30.00
15P	28.00	32.00

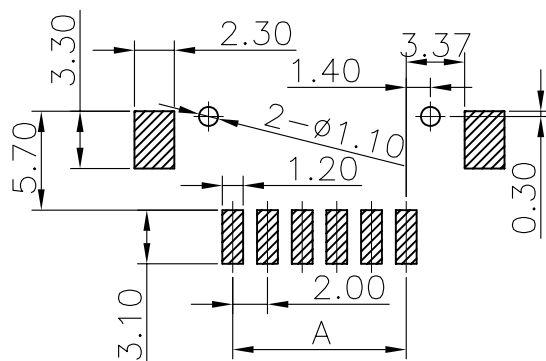

P.C.B LAYOUT

Unit: mm

				GENERAL TOLERANCES		SCALE: 1:1	NAME	DATE	东莞市康导新能源科技有限公司 DONGGUANG KD NEW ENERGY TECHNOLOGY CO., LTD. 公司地址: www.dgkonne.cn 公司电话: 0769-85337633 邮箱: 2850175986@qq.com 公司传真: 0769-86392827	PART. NO: 22003W90-NP*-XX-***	
				LINEAR	ANGLES	APPROVED				DWG. NO: ENDE05	
A0	新图面发行	2018.07.28	UNIT: MM	0.00±0.15	X° ±3°	DESIGNER			TITLE: 2.00mm pitch Single Wafer	REV: A0	SHEET: 1/1
REV.	REVISION RECORD	DATE	SIZE: A4	0.000±0.08	X° X'±2°	DRAWN	肖丽娟	2018.07.28			