

环保物料

Reference Informations:

\*Material: Pin: Brass/Tin-plated

Wafer: Nylon 6T, UL94V-0

Dimensional Information:

Part No.	Dimensions	
	A	B
2P	2.50	7.50
3P	5.00	10.00
4P	7.50	12.50
5P	10.00	15.00
6P	12.50	17.50
7P	15.00	20.00
8P	17.50	22.50
9P	20.00	25.00
10P	22.50	27.50
11P	25.00	30.00
12P	27.50	32.50
13P	30.00	35.00
14P	32.50	37.50
15P	35.00	40.00
16P	37.50	42.50

Unit: mm

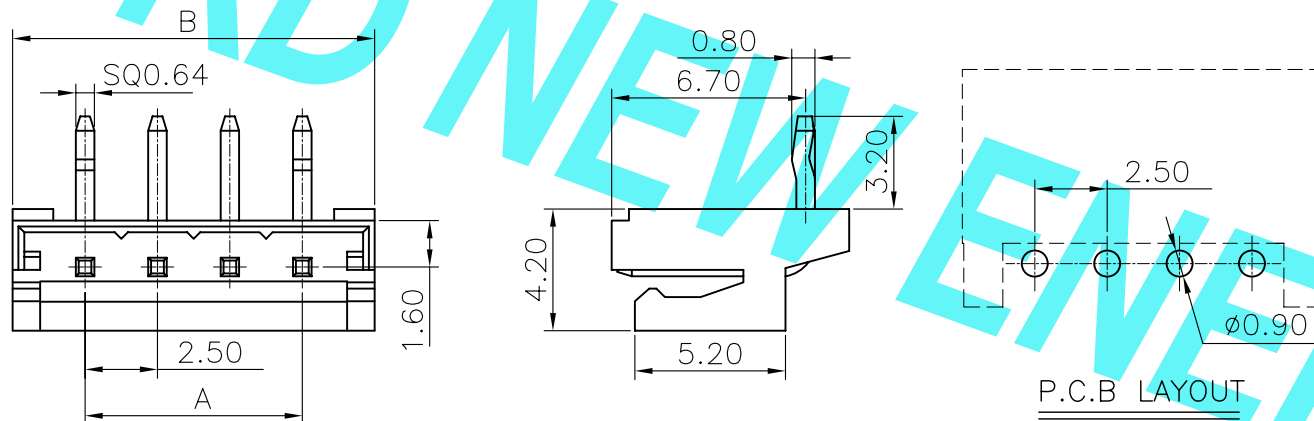

				GENERAL TOLERANCES		SCALE: 1:1	NAME	DATE	东莞市康导新能源科技有限公司 DONGGUANG KD NEW ENERGY TECHNOLOGY CO., LTD 公司地址: www.dgkonne.cn 公司电话: 0769-85337633 邮箱: 2860175988@qq.com 公司传真: 0769-85392827	PART. NO: 22502W90-NP-A1-***	
				LINEAR	ANGLES					APPROVED	
A0	新图面发行	2018.07.28	UNIT: MM	0.00±0.15	X° ±3°	DESIGNER			TITLE: 2.50mm pitch Single Wafer	REV: A0	SHEET: 1/1
REV.	REVISION RECORD	DATE	SIZE: A4	0.000±0.08	X° X'±2°	DRAWN	肖丽娟	2018.07.28			