

环保物料

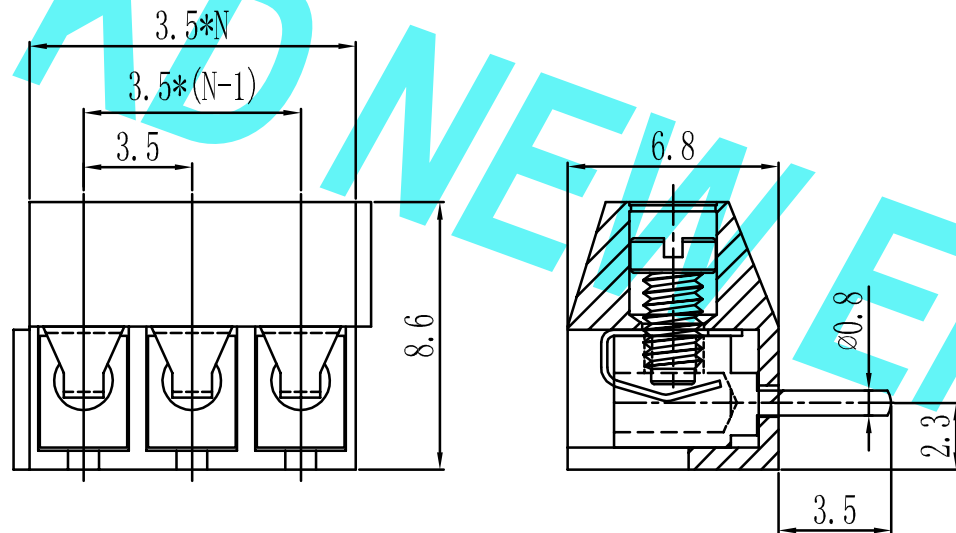

N=Number of Contacts

产品型号	MODEL	KD350R	
材质&电镀	MATERIAL&PLATING		
螺丝	Screw	M2.0, 钢, 镀锌 steel, Zinc Plated	
弹片	Reed	磷青铜镀镍或不锈钢 Phosphor Bronze, Ni plated or stainless steel	
焊针	Pin header	黄铜, 镀锡 Brass, Tin plated	
塑件	Housing	PA66, UL94V-0	
电气性能	ELECTRICAL	UL	IEC
额定电压	Rated voltage	300V	130V
额定电流	Rated current	16A	10A
接触电阻	Contact resistance	20mΩ	
绝缘电阻	Insulation resistance	500MΩ/1000V	
耐电压	Withstanding voltage	AC1250V/1min	
使用线径	Wire range	24-18AWG 1.0mm ²	
机械性能	MECHANICAL		
温度范围	Temp. range	-40°C ~ +105°C	
瞬时温度	Max. soldering	+250°C, 5sec	
扭矩	Torque	0.2N.m 1.7Lb.in	
剥线长度	Strip length	5-6mm	

				GENERAL TOLERANCES		SCALE: 1:1	NAME	DATE	 东莞市康导新能源科技有限公司 DONGGUAN KD NEW ENERGY TECHNOLOGY CO., LTD. 公司地址: www.dgconne.cn 公司电话: 0769-85337633 邮 箱: 2850175986@qq.com 公司传真: 0769-85392827	PART. NO:	KD350R	
				LINEAR	ANGLES	APPROVED				DWG. NO:	KDTB-0017	
AO	新图面发行	2019.02.14	UNIT: MM	0.00±0.15	X° ±3°	DESIGNER			TITLE:	3.50mm pitch EURO TERMINAL BLOCKS		
REV.	REVISION RECORD	DATE	SIZE: A4	0.000±0.08	X° X'±2°	DRAWN	肖丽娟	2019.02.14	REV:	AO	SHEET:	1/1