

环保物料

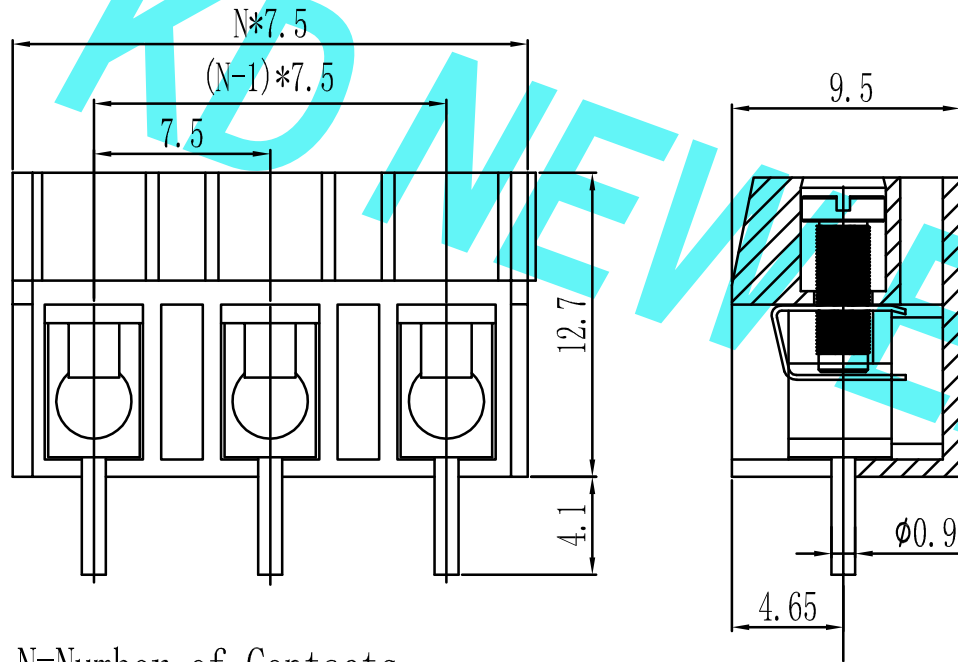

N=Number of Contacts

产品型号	MODEL	KD360	
材质&电镀	MATERIAL&PLATING		
螺丝	Screw	M3.0, 钢, 镀锌 steel, Zinc Plated	
弹片	Reed	磷青铜镀镍或不锈钢 Phosphor Bronze, Ni plated or stainless steel	
焊针	Pin header	黄铜, 镀锡 Brass, Tin plated	
塑件	Housing	PA66, UL94V-0	
电气性能	ELECTRICAL	UL	IEC
额定电压	Rated voltage	300V	450V
额定电流	Rated current	16A	24A
接触电阻	Contact resistance	20mΩ	
绝缘电阻	Insulation resistance	500MΩ/1000V	
耐电压	Withstanding voltage	AC2500V/1min	
使用线径	Wire range	22-14AWG 2.5mm <sup>2</sup>	
机械性能	MECHANICAL		
温度范围	Temp. range	-30℃~+105℃	
瞬时温度	Max. soldering	+250℃, 5sec	
扭矩	Torque	0.5N.m 4.4Lb.in	
剥线长度	Strip length	4.5-5mm	

				GENERAL TOLERANCES		SCALE:	NAME	DATE	 <b>东莞市康导新能源科技有限公司</b> DONGGUAN KID NEW ENERGY TECHNOLOGY CO., LTD. 公司网址: www.dgconne.cn 公司电话: 0769-85337633 邮 箱: 2850175986@qq.com 公司传真: 0769-85392827		PART. NO:	KD360		
				LINEAR 0.0±0.25 0.00±0.15 0.000±0.08		ANGLES X° REF±6° X° ±3° X° X'±2°		APPROVED			DWG. NO:	KDTB-0012		
AO	新图面发行	2019.02.14	UNIT: MM			DESIGNER			TITLE:			REV:	AO	SHEET: 1/1
REV.	REVISION RECORD	DATE	SIZE: A4			DRAWN	肖丽娟	2019.02.14	7.50mm pitch EURO TERMINAL BLOCKS					