

环保物料

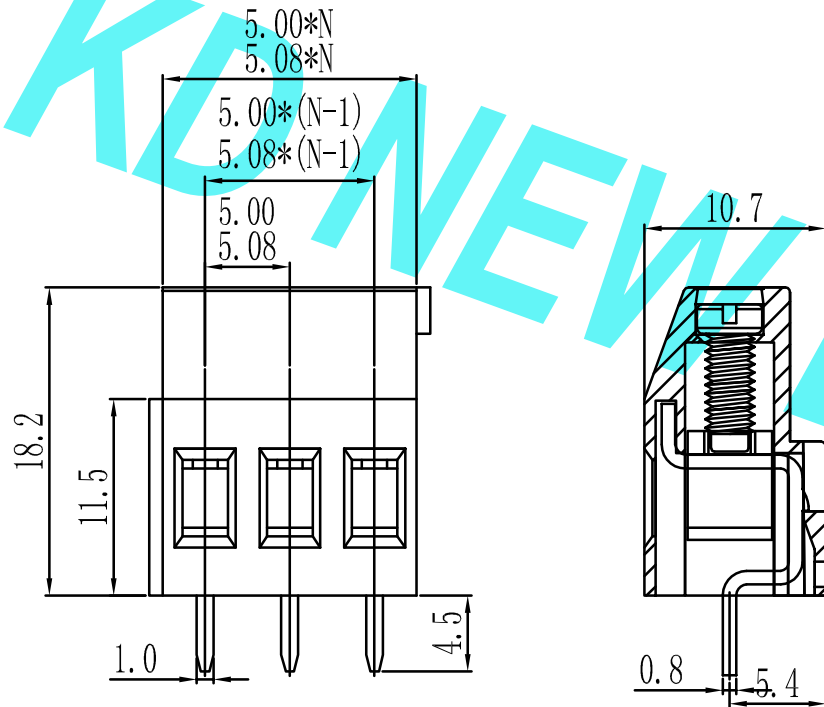

N=Number of Contacts

产品型号	MODEL	KD129V	
材质&电镀	MATERIAL&PLATING		
螺丝	Screw	M3.0, 钢, 镀锌 steel, Zinc Plated	
弹片	Reed	黄铜, 镀镍 Brass, Ni plated	
焊针	Pin header	黄铜, 镀锡 Brass, Tin plated	
塑件	Housing	PA66, UL94V-0	
电气性能	ELECTRICAL	UL	IEC
额定电压	Rated voltage	300V	250V
额定电流	Rated current	20A	20A
接触电阻	Contact resistance	20mΩ	
绝缘电阻	Insulation resistance	500MΩ/1000V	
耐电压	Withstanding voltage	AC2000V/1min	
使用线径	Wire range	24-12AWG 4.0mm ²	
机械性能	MECHANICAL		
温度范围	Temp. range	-40℃~+105℃	
瞬时温度	Max. soldering	+250℃, 5sec	
扭矩	Torque	0.5N.m 4.4lb.in	
剥线长度	Strip length	6-7mm	

				GENERAL TOLERANCES		SCALE:	NAME	DATE	东莞市康导新能源科技有限公司 DONGGUAN KD NEW ENERGY TECHNOLOGY CO., LTD. 公司网址: www.dgconne.cn 公司电话: 0769-85337633 邮 箱: 2850175986@qq.com 公司传真: 0769-85392827	PART. NO:	KD129V	
				LINEAR	ANGLES	1:1	APPROVED			DWG. NO:	KDTB-0050	
A0	新图面发行	2019.02.14	UNIT: MM	0.00±0.15	X° ±3°		DESIGNER		TITLE:	5.00/5.08mm pitch EURO TERMINAL BLOCKS		
REV.	REVISION RECORD	DATE	SIZE: A4	0.000±0.08	X° X'±2°		DRAWN	肖丽娟	2019.02.14	REV:	AO	SHEET: 1/1