

环保物料

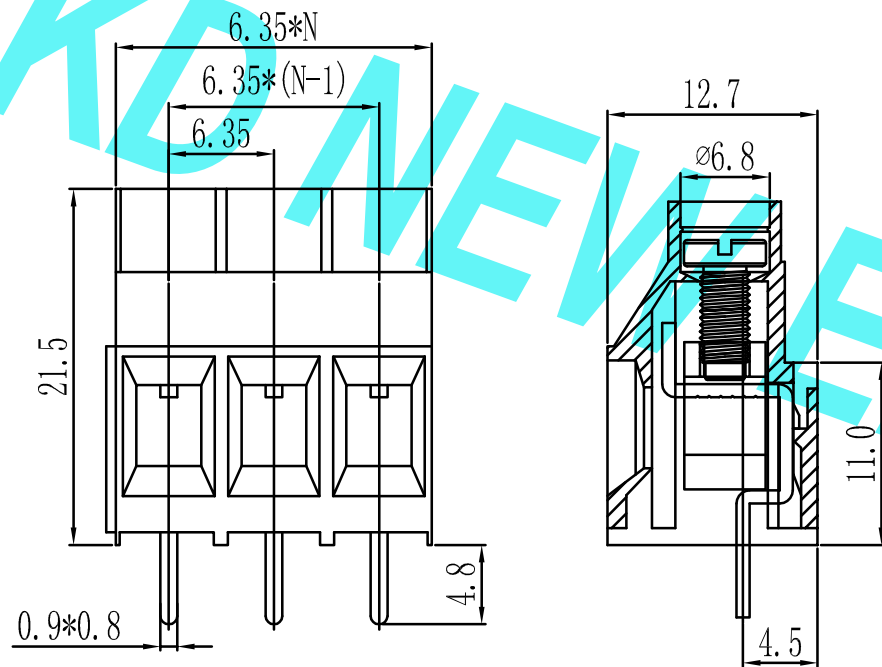

N=Number of Contacts

|       |                       |                                |      |
|-------|-----------------------|--------------------------------|------|
| 产品型号  | MODEL                 | KD635                          |      |
| 材质&电镀 | MATERIAL&PLATING      |                                |      |
| 螺丝    | Screw                 | M3.0, 钢, 镀锌 steel, Zinc Plated |      |
| 弹片    | Reed                  | 黄铜, 镀镍 Brass, Ni plated        |      |
| 焊针    | Pin header            | 黄铜, 镀锡 Brass, Tin plated       |      |
| 塑件    | Housing               | PA66, UL94V-0                  |      |
| 电气性能  | ELECTRICAL            | UL                             | IEC  |
| 额定电压  | Rated voltage         | 300V                           | 450V |
| 额定电流  | Rated current         | 30A                            | 24A  |
| 接触电阻  | Contact resistance    | 20mΩ                           |      |
| 绝缘电阻  | Insulation resistance | 500MΩ/1000V                    |      |
| 耐电压   | Withstanding voltage  | AC3000V/1min                   |      |
| 使用线径  | Wire range            | 26-10AWG 4.0mm <sup>2</sup>    |      |
| 机械性能  | MECHANICAL            |                                |      |
| 温度范围  | Temp. range           | -40℃~+105℃                     |      |
| 瞬时温度  | Max. soldering        | +250℃, 5sec                    |      |
| 扭矩    | Torque                | 0.5N.m 4.4Lb.in                |      |
| 剥线长度  | Strip length          | 6-7mm                          |      |

|      |                 |                    |          |            |          |       |  |            |                                   |           |            |
|------|-----------------|--------------------|----------|------------|----------|-------|--|------------|-----------------------------------|-----------|------------|
|      |                 | GENERAL TOLERANCES |          | SCALE:     | NAME     | DATE  | 东莞市康导新能源科技有限公司<br>DONGGUANG KD NEW ENERGY TECHNOLOGY CO., LTD.<br>公司网址: www.dgconne.cn 公司电话: 0769-85337633<br>邮 箱: 2850175986@qq.com 公司传真: 0769-85392827 |            | PART. NO:                         | KD635     |            |
|      |                 |                    |          | 0.0±0.25   | APPROVED |       |  |            | DWG. NO:                          | KDTB-0055 |            |
|      |                 |                    |          | X° REF±6°  | DESIGNER |       |  |            | REV:                              | AO        | SHEET: 1/1 |
| AO   | 新图面发行           | 2019.02.14         | UNIT: MM | 0.00±0.15  | X° ±3°   |       | TITLE:   |            | 6.35mm pitch EURO TERMINAL BLOCKS |           |            |
| REV. | REVISION RECORD | DATE               | SIZE: A4 | 0.000±0.08 | X° X'±2° | DRAWN | 肖丽娟  | 2019.02.14 |                                   |           |            |