

环保物料

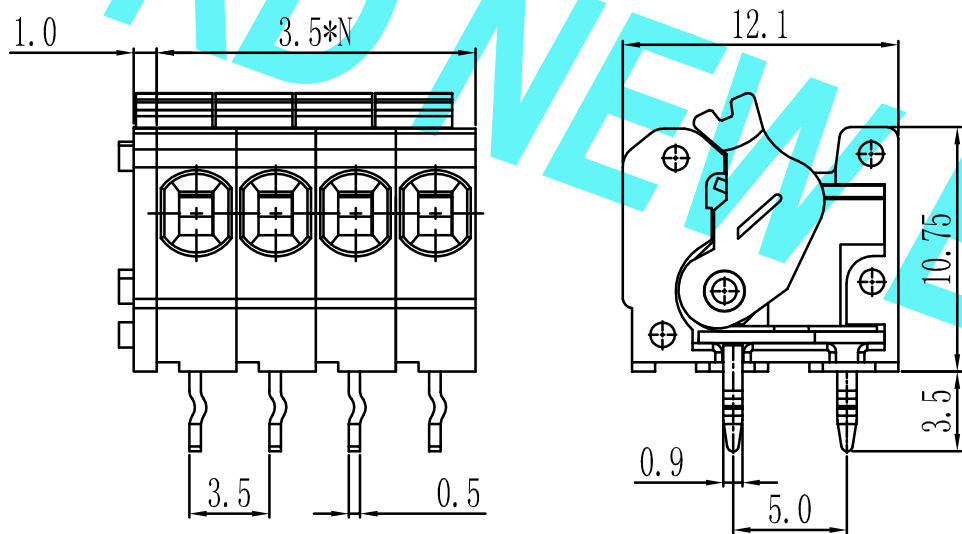

N=Number of Contacts

产品型号	MODEL	KD260	
材质&电镀	MATERIAL&PLATING		
螺丝	Screw	-	
弹片	Reed	不锈钢 Stainless steel	
焊针	Pin header	黄铜, 镀锡 Brass, Tin plated	
塑件	Housing	PA66, UL94V-0	
电气性能	ELECTRICAL	UL	IEC
额定电压	Rated voltage	300V	250V
额定电流	Rated current	7A	5A
接触电阻	Contact resistance	20mΩ	
绝缘电阻	Insulation resistance	500MΩ/1000V	
耐电压	Withstanding voltage	AC1500V/1min	
使用线径	Wire range	22-16AWG 1.5mm ²	
机械性能	MECHANICAL		
温度范围	Temp. range	-40°C~+105°C	
瞬时温度	Max. soldering	+250°C, 5sec	
扭矩	Torque	-	
剥线长度	Strip length	8-9mm	

				GENERAL TOLERANCES		SCALE: 1:1	NAME	DATE	东莞市康导新能源科技有限公司 DONGGUANG KD NEW ENERGY TECHNOLOGY CO., LTD. 公司网址: www.dgconne.cn 公司电话: 0769-85337633 邮 箱: 2850175986@qq.com 公司传真: 0769-85392827	PART. NO: KD260	
				LINEAR	ANGLES	APPROVED				DWG. NO: KDTB-0176	
A0	新图面发行	2019.02.23	UNIT: MM	0.00±0.15	X° ±3°	DESIGNER			TITLE: 3.50mm pitch SCREWLESS TERMINAL BLOCKS	REV: A0	SHEET: 1/1
REV.	REVISION RECORD	DATE	SIZE: A4	0.000±0.08	X° X'±2°	DRAWN	肖丽娟	2019.02.23			