

环保物料

产品型号	MODEL	HB-950
材质&电镀	MATERIAL&PLATING	
螺丝	Screw	M4.0, 钢, 镀镍 Steel, Nickel Plated
端子	Terminal	黄铜, 0.8t 镀锡 Brass, Tin Plated
塑件	Housing	PA66, UL94V-0
电气性能	ELECTRICAL	
额定电压	Rated voltage	300V
额定电流	Rated current	25A
绝缘电阻	Insulation resistance	500MΩ/DC500V
耐电压	Withstanding voltage	AC2000V/1min
使用线径	Wire range	22-12AWG 4.0mm <sup>2</sup>
机械性能	MECHANICAL	
温度范围	Temp. range	-40℃~+105℃
扭矩	Torque	1.2N.m 10.53Lb.in

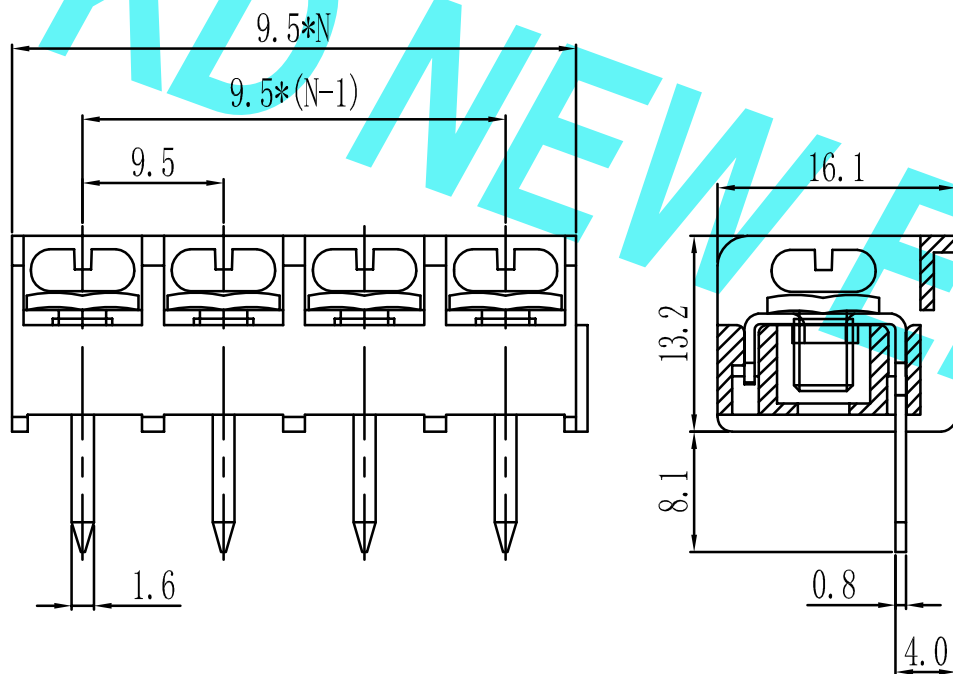

N=Number of Contacts

				GENERAL TOLERANCES		SCALE: 1:1	NAME	DATE	 <b>东莞市康导新能源科技有限公司</b> DONGGUAN ED NEW ENERGY TECHNOLOGY CO., LTD. 公司网址: www.dgconne.cn 公司电话: 0769-85337633 邮 箱: 2850175986@qq.com 公司传真: 0769-85392827	PART. NO:	HB-950
				LINEAR	ANGLES	APPROVED				DWG. NO:	KDTB-0255
A0	新图面发行	2019.02.25	UNIT: MM	0.00±0.15	X° ±3°	DESIGNER			TITLE:	9.50mm pitch AMERICAN/JAPANESE TERMINAL BLOCKS	
REV.	REVISION RECORD	DATE	SIZE: A4	0.000±0.08	X° X'±2°	DRAWN	肖丽娟	2019.02.25	REV:	A0	SHEET: 1/1